

WG-7™ Closure

WG-7 closure and WG-7 adhesive closure
For panel opening filler

- The original industry closure material — time tested-millions of feet installed over the last 30-plus years.
- Polyethylene foam for exceptional strength and compressibility.
- Most configurations are cut with dovetails that eliminate gapping between pieces.
- Moisture and water vapor transmission is barely measurable.
- Adhesive applied to the contact side of the panel surface assures positive positioning during installation.
- Resist damaging ultra violet rays and ozone deterioration.
- Over 1800 panel configurations available.
- Manufactured in multiple plants for quick delivery.

Application

WG-7 Closure

Material Thickness: 1", 1-1/2", 2"

Color: Grey

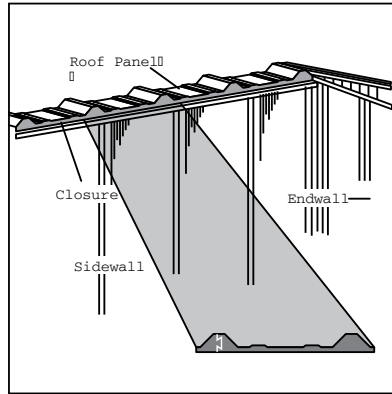

Typical Inside Closure Application

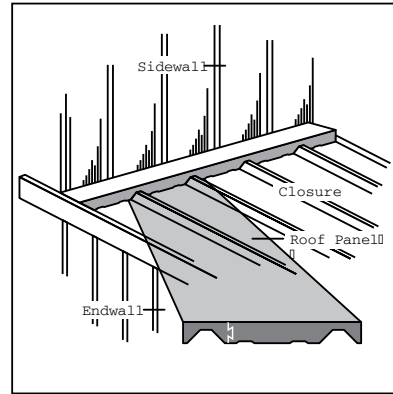

Typical Outside Closure Application

Features

Property	Units	Properties*
Nominal density Skin/Skin	lb/ft³	1.5 – 2.0
Recommended operating temperature range	degrees F	+212 max -94 min
Compression stress-strain characteristics		
10% compression	psi	4.64
25% compression	psi	7.54
50% compression	psi	16.53
Compression set (22 hrs, 25% compression, 23°C)		
1/2 hour recovery	% set	12
24 hour recovery		5
Tear strength	ft-lbs	295
Tensile strength	psi	46.27
Elongation	%	102
Thermal conductivity (at mean temp of 50° F)		
	BTU/ft-hr.-degrees F	0.023
Horizontal Burning Characteristics		
0.197" thickness	in/sec	0.083
0.512" thickness	in/sec	0.059
FMVSS.302 (pass thickness)	in	0.394" and above
Shore Hardness 00 scale (min. 0.394" cell/cell thickness)		
		43

*All properties are nominal values and are subject to change.

Options

None